

RAVAS Ergo-Truck 2

Hand pallet truck with electric drive

MOBILE
WEIGHING
SYSTEM

RAVAS Ergo-Truck 2

The RAVAS Ergo-Truck 2 is an electric pallet truck suitable for a wide variety of applications, from occasional to intensive use, from standard to large loads. The RAVAS Ergo-Truck 2 offers the possibility of two Li-ion 24V/20Ah batteries, which maximizes the operating time. The system is equipped as standard with two stabilizing wheels. This allows larger loads to be processed and also reduces the risk of tipping and damages.

BENEFITS

- Mobile-Scale truck with electric power drive
- Allrounder for diverse applications
- Full electric lifting and lowering
- High accuracy scale functionalities
- Combines weighing and moving in one truck
- Power supply truck via 24V/20Ah Li-ion (exchangeable) battery pack
- Moves loads > 750 kg easily, with a maximum of 1,500kg
- Reduce operator effort and increase efficiency
- Removable storage compartment
- Available with indicator 3200

Top quality

Easy to move



RAVAS Ergo-Truck 2

STANDARD SCALE SPECIFICATIONS

- Weighing capacity 1,500 kg
- Graduation multirange
0 - 500 kg; 0.5 kg
500 - 1,500 kg; 1 kg
- System tolerance 0,1% of applied load
- Display LCD dual color, backlight, digit height 20 mm
- Power consumption 12V - 34mA
- Power supply via truck battery incl. power convertor/regulator
- Keys 5 function keys, on/off key
- Protection class system IP65
- Dimensions L x B x H = 60 x 77 x 182 (excl. bracket)

STANDARD TRUCK SPECIFICATIONS

- Li-ion battery 24V/20Ah, incl. separate charger
- Autonomy battery up to 5,5 hours working at one charge; depending on work and environmental conditions
- Standard equipped with stability wheels
- Driving wheel polyurethane 210 x 70 mm
- Dual loading wheels polyurethane 80 x 60 mm (74 x 30)
- Driving motor 0,75 kW
- Lifting motor 0,5 kW
- Lifting speed (loading/unloading) 0,017-0,02 m/s
- Lowering speed (loading/unloading) 0,058-0,046 m/s
- Travel speed (loading/unloading) 4-4,5 km/h
- Buzzer, battery indicator (without time)

OPTIONS

- Second Li-ion battery to maximize uptime
- Legal for trade version
- Bluetooth and WiFi data transfer
- Thermal or matrix printer 12V
- RDC, RAVAS Data Collector Software
- RIS, RAVAS Integration Software

DIMENSIONS IN MM

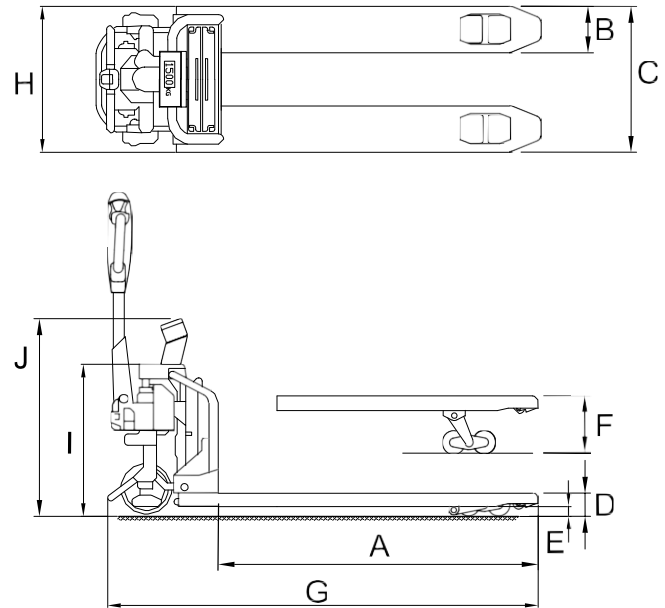

A	Fork length	1150
B	Fork width	155
C	Width over forks	560
D	Lowered fork height	90
E	Ground clearance	20
F	Lifting height	195
G	Total truck length	1600
H	Truck width	585
I	Truck height	610
J	Height center display	800
	Own weight (kg)	160

Tolerance +/- 2 mm

Maximum capacity specified at load center point 600 mm*



RAVAS
creating intelligence

RAVAS EUROPE BV

Veilingweg 17
5301 KM Zaltbommel
The Netherlands

+31 418 515220
salesoffice@ravas.com
www.ravas.com